



Operating Manual

Tradesmig 165/235/245 & 285



**Please ensure that this
Instruction Manual is made
available to the user of
the equipment**



Contents

	Page
● Warnings	4
● Safety	5
● Introduction	7
● Installation	8
● Operation	11
● Specification	14
● Circuit Diagrams	15
● Maintenance	18
● Spare Parts	19

DECLARATION OF CONFORMITY

Murex Welding Products Ltd

Declare hereby that:

Murex Tradesmig 165, 235, 245 & 285 power sources

Part No: 1413406, 1413416, 1413421 & 1413426

From Production Serial No. 96Axxxxx

- are manufactured in accordance with the Council Directive 73/23/EEC (1973-02-19) and 89/336/EEC (1989-05-03) amended by Council Directive 93/68/EEC relating to electrical equipment designed for use within certain voltage limits.
- conform with the protection requirements of Council Directive 89/336/EEC, amended by Council Directives 91/263/EEC, 92/31/EEC and 93/68/EEC relating to electromagnetic compatibility.
- are manufactured in accordance with EN60974-1 Safety Requirements for Arc Welding Equipment
- are manufactured in accordance with EN50199 Electromagnetic Compatibility for Arc Welding Equipment.

On behalf of Murex Welding Products Ltd
Hertford Road
Waltham Cross
Herts. EN8 7RP
England



P.G. Dodd
Managing Director
Date: 1-12- 1995



WARNING



This welding equipment has been designed, manufactured and tested to the highest standards to ensure long and trouble free life. However, regular maintenance is an essential part of keeping the machine operating in a reliable and safe manner and your attention is drawn to any maintenance instructions that are contained in this manual.

In general, all welding equipment should be thoroughly inspected, tested and serviced at least annually. More frequent checking will be required when the equipment is heavily used.

Wear and tear, particularly in electro-mechanical and moving components, are gradual processes. Caught in time, repair costs are small and the benefits in performance reliability and safety are significant. Left alone, they can put the equipment, and you, at risk.

Have this equipment regularly inspected and maintained by an approved service centre.



WARNING



ARC WELDING AND CUTTING CAN BE INJURIOUS TO YOURSELF AND OTHERS. TAKE PRECAUTIONS WHEN WELDING. ASK FOR YOUR EMPLOYER'S SAFETY PRACTICES WHICH SHOULD BE BASED ON MANUFACTURERS' HAZARD DATA.

ELECTRIC SHOCK - Can Kill

- Install and earth the welding unit in accordance with applicable standards.
- Do not touch live electrical parts or electrodes with bare skin, wet gloves, or wet clothing.
- Insulate yourself from earth and work.
- Ensure your working position is secure.

FUMES AND GASES – Can be Dangerous to Health

- Keep your head out of the fumes.
- Use ventilation, extraction at the arc, or both, to keep fumes and gases from your breathing zone and the general area.

ARC RAYS – Can Injure Eyes and Burn Skin

- Protect your eyes and body. Use the correct welding screen and filter lens and wear protective clothing.
- Protect bystanders with suitable screens or curtains.

NOISE– Excessive noise can damage hearing

- Protect your ears. Use ear defenders or other hearing protection.
- Warn bystanders of the risks.

**READ AND UNDERSTAND THE INSTRUCTION MANUAL
BEFORE INSTALLING OR OPERATING AND SEE WMA PUBLICATION 237
'The arc welder at work' AVAILABLE FROM THE MANUFACTURER.**

PROTECT YOURSELF AND OTHERS

SAFETY

In any arc welding or cutting operation, it is the responsibility of the user to observe certain safety rules to ensure his personal safety and to protect those working near him.

Read all safety articles relevant to arc welding or cutting published by the WMA. Pay particular attention to any CAUTION or WARNING Notes included in this manual. CAUTION indicates possible equipment damage. WARNING indicates possible hazard to life.

⚠ WARNING ⚠

The ON/OFF switch on this equipment does not isolate the unit from the mains electrical supply. **AC POWER IS PRESENT ON THE ON/OFF SWITCH TERMINALS.**

The On/Off lamp is an indication that the supply is switched on and does not imply that the unit is isolated from the supply. **BEFORE REMOVING THE COVERS FOR MAINTENANCE, ISOLATE THE UNIT FROM THE MAINS ELECTRICAL SUPPLY.**

1. Electrical

- ⚠ Treat electricity with respect. Even the open circuit voltage of this equipment can be dangerous. Adjustments to the torch or replacement of torch parts should be undertaken with the mains supply isolated from the unit.
- If damaged torch cables or torch components are found, the unit must be disconnected from the mains and defective parts must be replaced using only Murex spare parts.
- ⚠ Do not work on live circuits or cables. Disconnect the main power supply before checking the machine or performing any maintenance operation.
- ⚠ Be sure the case of the welding machine is properly connected to a good electrical earth.
- ⚠ Have the wiring for the welding machine installed by a qualified electrician. All connections must be made according to specifications in force and to general safety standards.
- ⚠ Do not stand in water or on damp floors while using an arc welder or cutter. Do not use in the rain.
- ⚠ Do not operate with worn or poorly connected cables. Inspect all cables frequently for insulation failure, exposed wires and loose connections.
- ⚠ Do not overload cables or continue to operate with overheating cables. Cables which are too small for the current carried will overheat, causing rapid deterioration of the insulation.
- ⚠ Pay attention that live parts of the torch do not touch any metal which is connected to the earth cable. Fix an insulated hook to hang the torch on when it is not in use.

1. Ventilation

- ⚠ Do not weld or cut on containers which have held combustible or flammable materials, or materials which give off flammable or toxic vapours when heated, without proper cleaning.
- ⚠ Locate the welding/cutting operation far enough from any vapour-type degreaser using trichlorethylene or other chlorinated hydrocarbons as solvents. The ultraviolet light from the arc can decompose these vapours into toxic gases at a considerable distance from the arc, even though the concentration of the gases is low enough to be undetectable by smell.
- ⚠ Be sure to provide adequate ventilation for removal and dilution of fume and gases. Fume exhaust facilities near the arc, or a ventilated helmet should be used when cutting in confined spaces or on toxic material.

2. Glare

- ⚠ Never look at the arc without wearing eye protection. Always use the proper protective clothing, filter glasses, and gloves. Be careful to avoid exposed skin areas. Do not use cracked or defective helmets or shields.
- ⚠ Never strike an arc when there is someone near who is not protected from the strong light of the arc.
- ⚠ Warn bystanders who are not aware of the dangers of ultraviolet light.

3. General

- ⚠ Take care when lifting the unit.
- ⚠ Ensure that cylinders are secured by chains.
- ⚠ Locate the unit so that there is adequate air flow to the ventilation louvres.
- ⚠ Always dress correctly to protect against glare, radiation and spatter.

4. Fire

- ⚠ Ensure that the correct type of fire extinguisher is available in the operating area.
- ⚠ Do not use near flammable materials or liquids, in or near explosive atmospheres, or on pipes carrying explosive gases.

5. Vehicle Electrics

- ⚠ When working on motor vehicles, remove the battery and any circuitry which may be damaged by the arc.
- ⚠ Whilst cutting be aware of the possibility of 'hidden wires' behind panels or bulkheads.

SAFETY - Your attention is drawn to the safety leaflets available from the Welding Institute, particularly publication 236 and 237

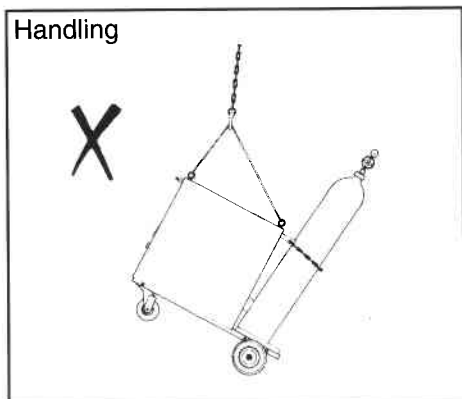

Remove cylinder before lifting

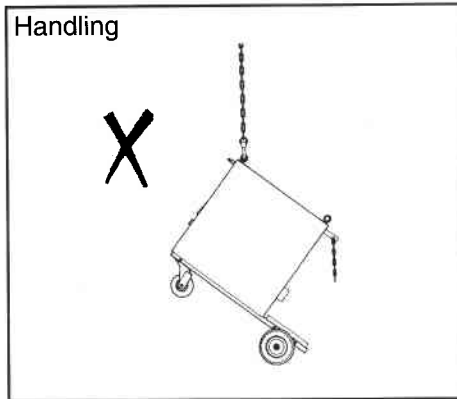

Do not lift using handle

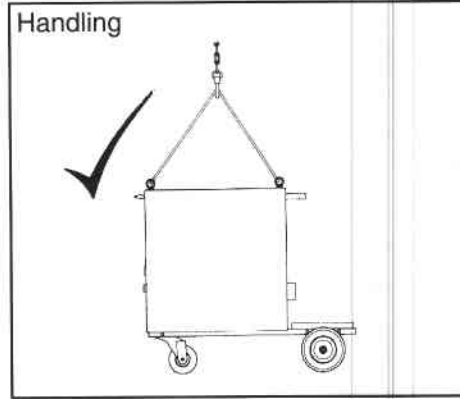

Lift the unit correctly

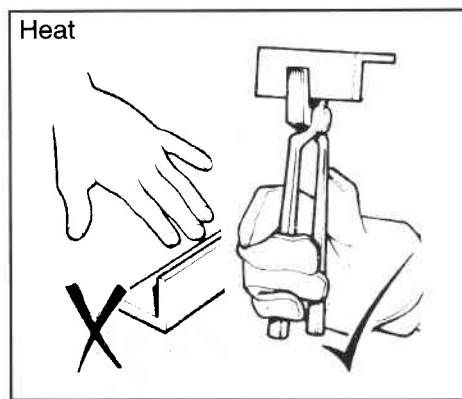

Don't burn yourself! Wear gauntlets and use tongs

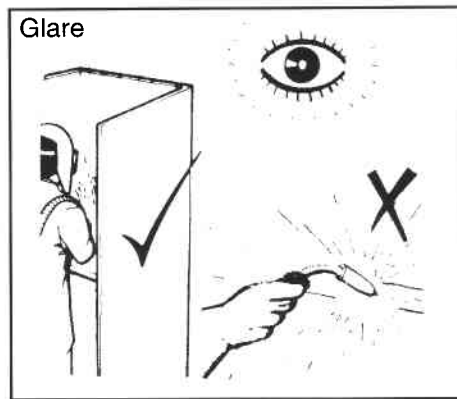

Wear your headshield (or face screen) and screen the welding area

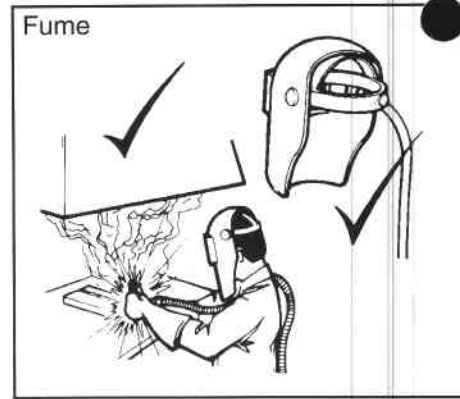

Ventilate the welding area to prevent a build-up of gas and fumes

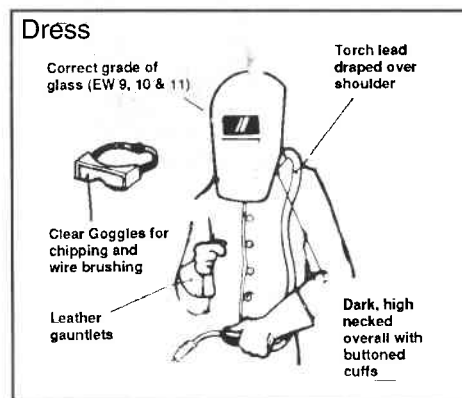

Dress correctly when welding and preparing the weld

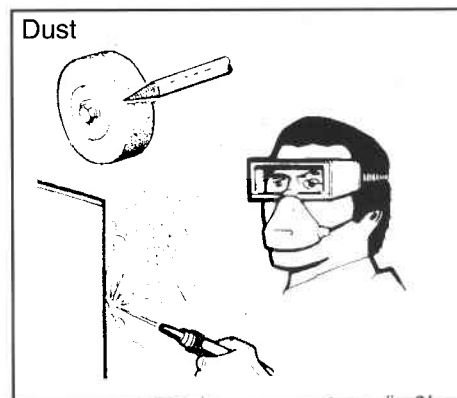

Wear goggles and mask when removing dust with an airline

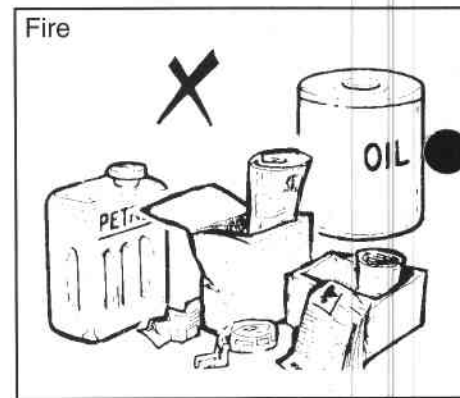

Before commencing welding, clear the area of flammable materials

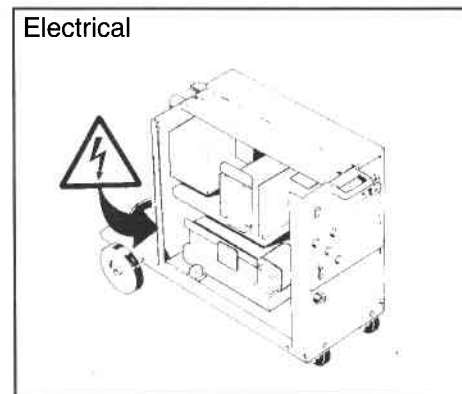

Don't work with the cover off. Leave it to the experts

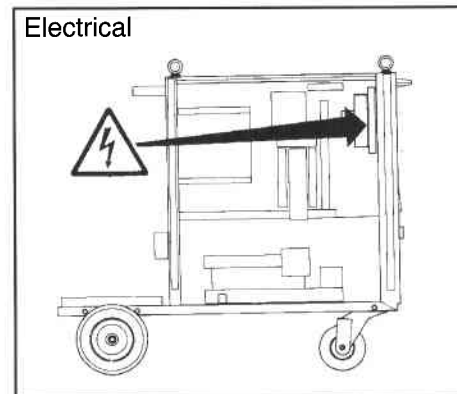

220V a.c. is supplied to the p.c.b. Isolate the unit before removing covers of p.c.b

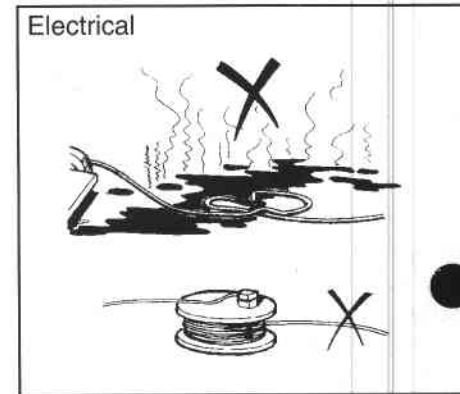

Don't allow leads to lie in oil, water or corrosive liquid, or extend them with extension leads - fit a longer cable

INTRODUCTION

The Tradesmigs 165, 235, 245 and 285 are Transformer/Rectifier MIG/MAG welding power sources fitted with an integral wire feed system. All five units are capable of continuous, spot and stitch welding using CO₂ or Argon rich gases.

A 42volt a.c. output is available to power a CO₂ heater - see page 4.

Protection against the effects of overheating is provided by thermal protection devices mounted on the transformer assembly and rectifier bridge. In the event of overheating, power to the unit is interrupted and the fault lamp is illuminated. The protective devices automatically reset once the unit cools.

NOTE

If the fault light comes on whilst welding, do not switch off but leave the unit switched on with the fan running until the protection devices reset. If the fault persists, call for technical assistance.

In the event of a mains input current surge, circuit breakers, mounted on the back panel, will interrupt a.c. supplies within the unit. These circuit breakers must be reset manually before the unit will function.

WARNING!

If the circuit breaker(s) trip and the fault lamp lights more than once or the fault lamp lights repeatedly after resetting, isolate the unit from the mains supply (remove the supply fuses) and call for technical assistance (from your Murex Service Centre Network).

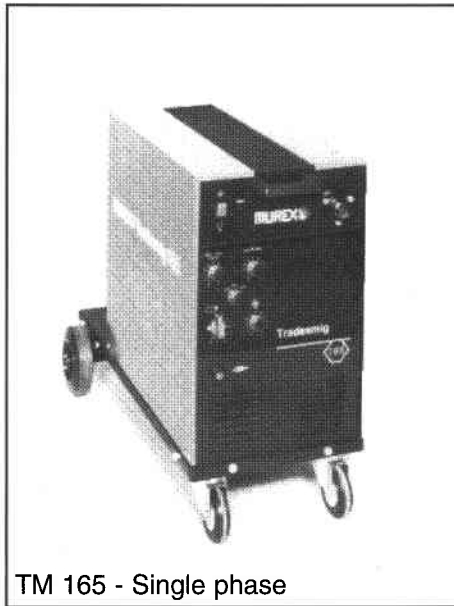

TM 165 - Single phase

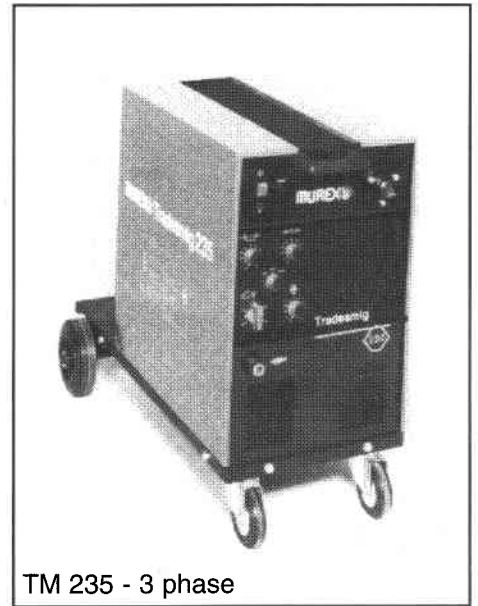

TM 235 - 3 phase

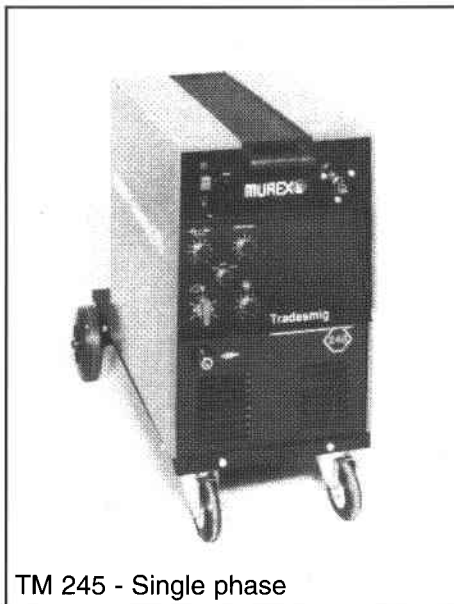

TM 245 - Single phase

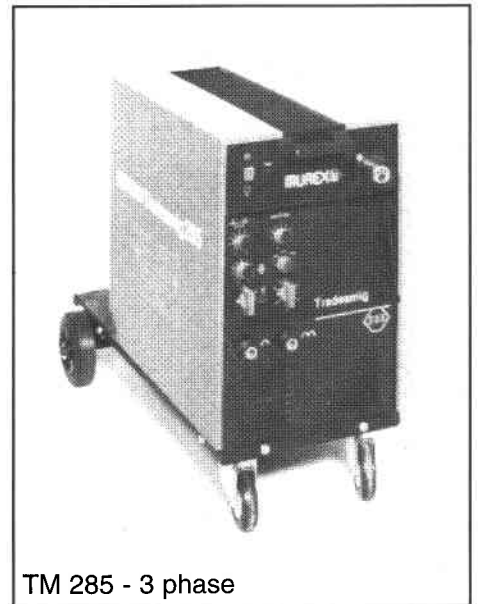

TM 285 - 3 phase

INSTALLATION

Installation must only be undertaken by a qualified electrician or suitably trained person.

Ventilation

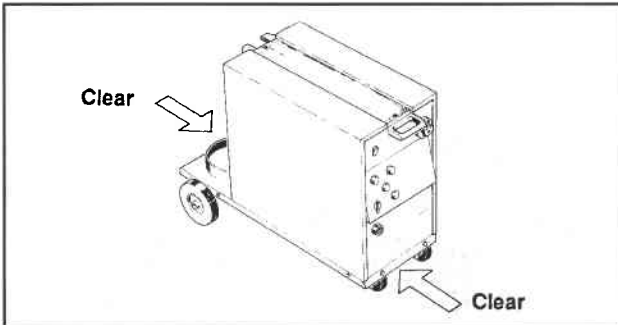

Place the unit so that the vents are clear of any obstruction to ventilating air.

Working area preparation

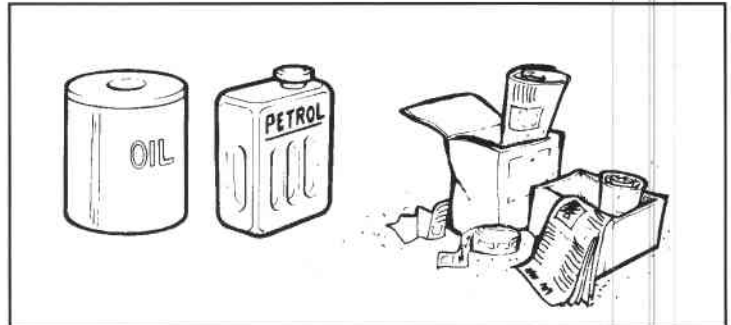

Remove all flammable materials from the area.

Electrical Connections

Remove the cover to expose the mains input selection and termination. Set the mains input selection links to suit the local mains supply voltage.

If the mains cable is not fitted, connect it to the mains input terminal block leaving sufficient slack in the earth wire.

Clamp the cable firmly.

42Vac Heater Connection TM 165, 235, 245, 285.

Feed the cable through the grommet in the back panel and connect the wires to the terminal block as shown. Clamp the cable firmly in the panel mounted clamp provided.

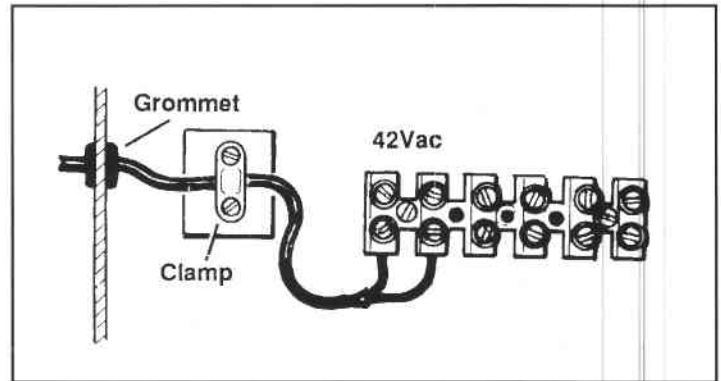

Tradesmig 235 and 285

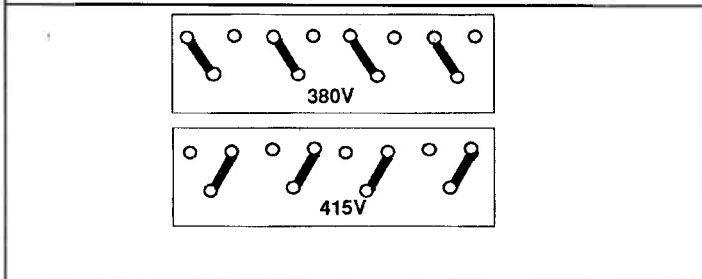
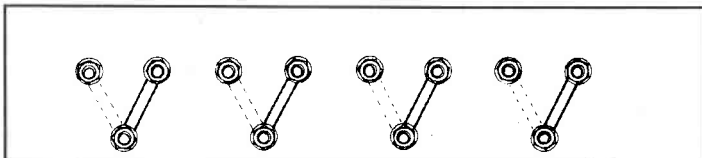
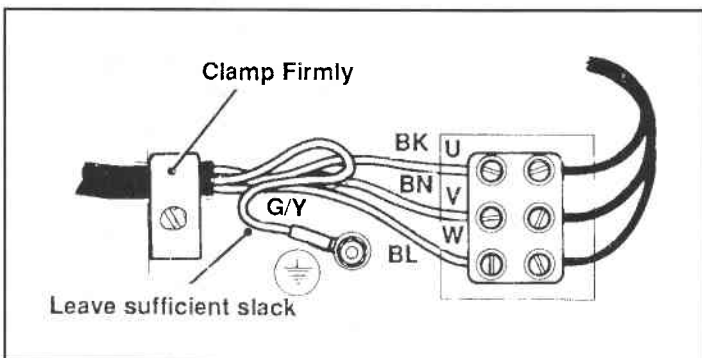

Tradesmig 165 and 245

